

MANUAL

IQT1-*-IO-V1

IO-Link

RFID Read/Write Stations

13.56 MHz



With regard to the supply of products, the current issue of the following document is applicable: The General Terms of Delivery for Products and Services of the Electrical Industry, published by the Central Association of the Electrical Industry (Zentralverband Elektrotechnik und Elektroindustrie (ZVEI) e.V.) in its most recent version as well as the supplementary clause: "Expanded reservation of proprietorship"

1	Safety	5
1.1	Introduction	5
1.1.1	Content of this Document	5
1.1.2	Manufacturer.....	5
1.1.3	Target Group, Personnel	5
1.1.4	Symbols Used.....	6
2	Certificates and Approvals	7
2.1	FCC and IC Information	7
2.2	Copyright	7
3	Product Description	8
3.1	Product Description.....	8
3.2	Dimensions.....	11
3.3	Indicators	12
3.4	Electrical Connection	12
3.5	IO-Link Interface Properties.....	12
3.6	Accessories	12
4	Installation.....	14
4.1	Storage and Transportation	14
4.2	Unpacking.....	14
4.3	Mounting and Connecting the Read/Write Station.....	14
5	Operation.....	16
5.1	Definitions.....	16
5.2	Read/Write Tags 13,56 MHz ISO15693	16
5.3	Easy Mode	18
5.4	Command Overview	18
5.4.1	Easy Mode Data Structure	18
5.4.2	IO-Link Process Data	20
5.4.3	Flow Diagrams.....	22
5.4.4	Timing.....	26



- 5.5 Easy Mode with PACTware..... 27
- 5.6 Expert Mode..... 30
- 6 Appendix 31
 - 6.1 IO-Link Parameters..... 31
 - 6.2 Error Repair..... 33
 - 6.3 ASCII Table 34



1 Safety

1.1 Introduction

1.1.1 Content of this Document

This document contains information required to use the product in the relevant phases of the product life cycle. This may include information on the following:

- Product identification
- Delivery, transport, and storage
- Mounting and installation
- Commissioning and operation
- Maintenance and repair
- Troubleshooting
- Dismounting
- Disposal



Note!

For full information on the product, refer to the further documentation on the Internet at www.pepperl-fuchs.com.

The documentation comprises the following parts:

- This document
- Datasheet

In addition, the documentation may comprise the following parts, if applicable:

- EU-type examination certificate
- EU declaration of conformity
- Attestation of conformity
- Certificates
- Control drawings
- Instruction manual
- Other documents

1.1.2 Manufacturer

Pepperl+Fuchs GmbH Lilienthalstraße 200, 68307 Mannheim, Germany

Internet: www.pepperl-fuchs.com
--

1.1.3 Target Group, Personnel

Responsibility for planning, assembly, commissioning, operation, maintenance, and dismounting lies with the plant operator.

Only appropriately trained and qualified personnel may carry out mounting, installation, commissioning, operation, maintenance, and dismounting of the product. The personnel must have read and understood the instruction manual and the further documentation.

Prior to using the product make yourself familiar with it. Read the document carefully.



1.1.4 Symbols Used

This document contains symbols for the identification of warning messages and of informative messages.

Warning Messages

You will find warning messages, whenever dangers may arise from your actions. It is mandatory that you observe these warning messages for your personal safety and in order to avoid property damage.

Depending on the risk level, the warning messages are displayed in descending order as follows:



Danger!

This symbol indicates an imminent danger.

Non-observance will result in personal injury or death.



Warning!

This symbol indicates a possible fault or danger.

Non-observance may cause personal injury or serious property damage.



Caution!

This symbol indicates a possible fault.

Non-observance could interrupt the device and any connected systems and plants, or result in their complete failure.

Informative Symbols



Note!

This symbol brings important information to your attention.



Action

This symbol indicates a paragraph with instructions. You are prompted to perform an action or a sequence of actions.

2 Certificates and approvals

2.1 FCC and IC Information

NOTICE:

This device complies with Part 15 of the FCC Rules and with Industry Canada license-exempt RSS standard(s).

Operation is subject to the following two conditions:

1. This device may not cause harmful interference, and
2. This device must accept any interference received, including interference that may cause undesired operation.

Le présent appareil est conforme aux CNR d'Industrie Canada applicables aux appareils radio exempts de licence. L'exploitation est autorisée aux deux conditions suivantes:

1. l'appareil ne doit pas produire de brouillage, et
2. l'appareil doit accepter tout brouillage radioélectrique subi, même si le brouillage est susceptible d'en compromettre le fonctionnement.

NOTICE:

Changes or modifications made to this equipment not expressly approved by the manufacturer may void the FCC authorization to operate this equipment.

Note:

This equipment has been tested and found to comply with the limits for a Class A digital device, pursuant to Part 15 of the FCC Rules. These limits are designed to provide reasonable protection against harmful interference when the equipment is operated in a commercial environment. This equipment generates, uses, and can radiate radio frequency energy and, if not installed and used in accordance with the instruction manual, may cause harmful interference to radio communications. Operation of this equipment in a residential area is likely to cause harmful interference in which case the user will be required to correct the interference at his own expense.

2.2 Copyright

The MIT License (MIT) Embedded Template Library.

<https://github.com/ETL CPP/etl>

Copyright © 2014 jwellbelove

Permission is hereby granted, free of charge, to any person obtaining a copy of this software and associated documentation files (the "Software"), to deal in the Software without restriction, including without limitation the rights to use, copy, modify, merge, publish, distribute, sublicense, and / or sell copies of the Software, and to permit persons to whom the Software is furnished to do so, subject to the following conditions:

The above copyright notice and this permission notice shall be included in all copies or substantial portions of the Software.

THE SOFTWARE IS PROVIDED "AS IS", WITHOUT WARRANTY OF ANY KIND, EXPRESS OR IMPLIED, INCLUDING BUT NOT LIMITED TO THE WARRANTIES OF MERCHANTABILITY, FITNESS FOR A PARTICULAR PURPOSE AND NONINFRINGEMENT. IN NO EVENT SHALL THE AUTHORS OR COPYRIGHT HOLDERS BE LIABLE FOR ANY CLAIM, DAMAGES OR OTHER LIABILITY, WHETHER IN AN ACTION OF CONTRACT, TORT OR OTHERWISE, ARISING FROM, OUT OF OR IN CONNECTION WITH THE SOFTWARE OR THE USE OR OTHER DEALINGS IN THE SOFTWARE.



3 Product Description

3.1 Product Description

Use and Application

These devices are RFID read/write stations with an IO-Link communication interface (IO-Link device). The RFID read/write stations read and write tags in the frequency range of 13.56 MHz according to the standard ISO 15693. The RFID read/write stations IQT1-...-IO-V1 are connected to an IO-Link master via an integrated M12 plug.

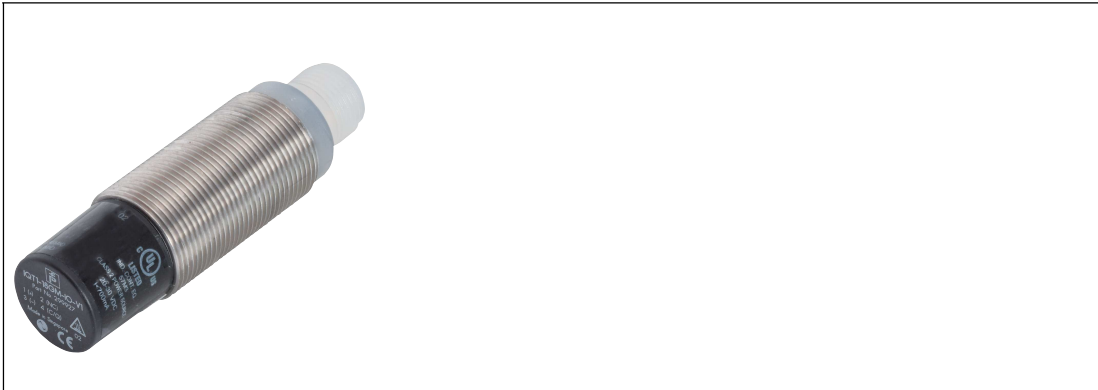

Figure 3.1 IQT1-18GM-IO-V1

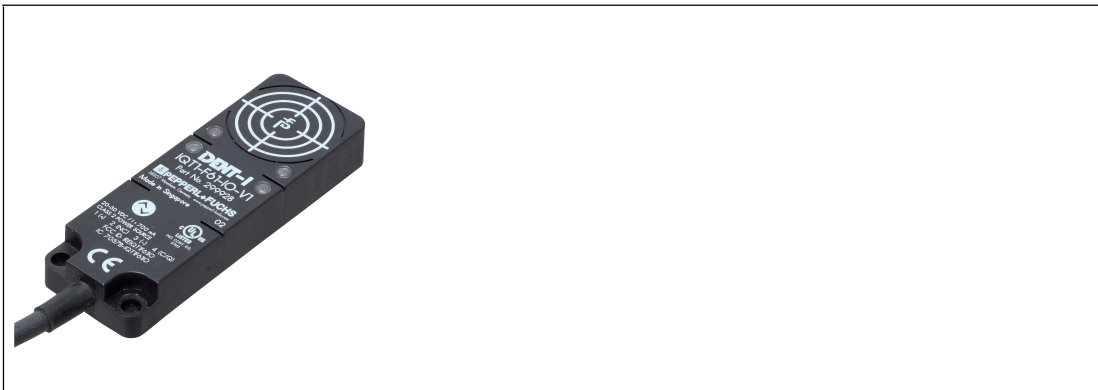

Figure 3.2 IQT1-F61-IO-V1



Figure 3.3 IQT1-FP-IO-V1

Scope of Delivery

The scope of delivery of the RFID read/write station IQT1-...-IO-V1 includes:

1. IQT1-...-IO-V1 IO-Link device
2. Mounting material 2 x M18 nuts (for IQT1-18GM-IO-V1)

3.2

Dimensions

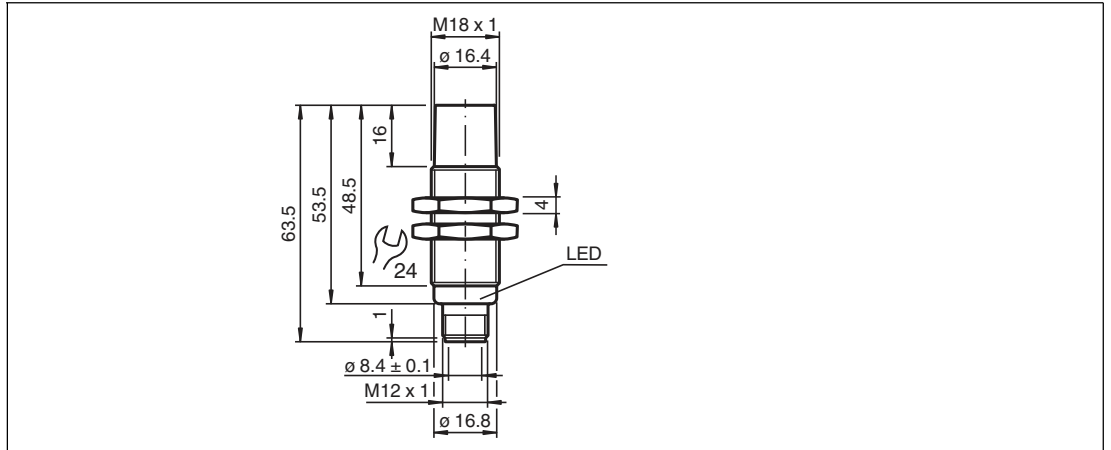

Figure 3.4 IQT1-18GM-IO-V1

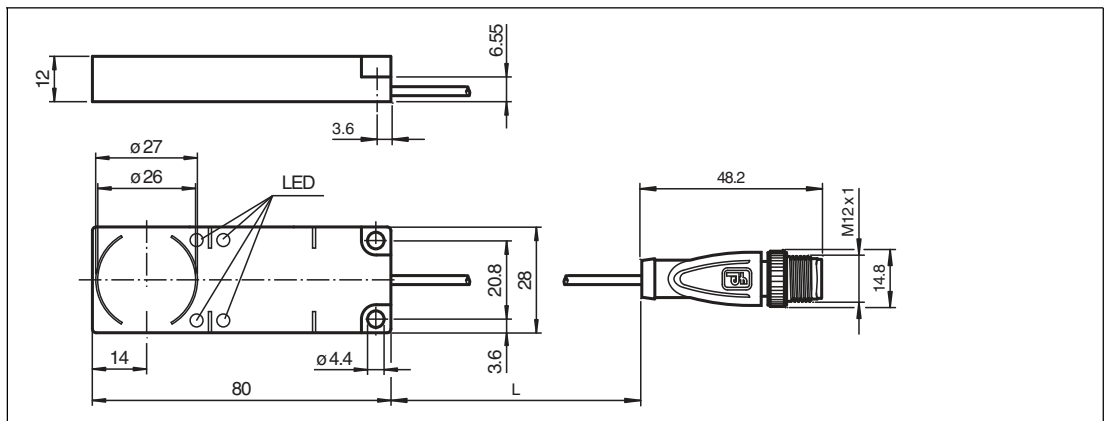

Figure 3.5 IQT1-F61-IO-V1

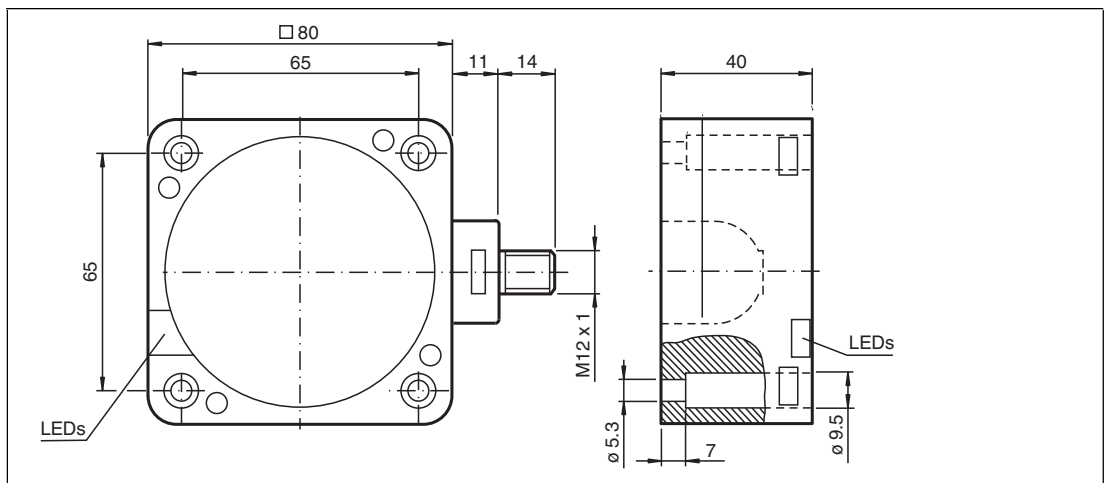

Figure 3.6 IQT1-FP-IO-V1

3.3 Indicators

The RFID read/write stations have LEDs to indicate the operating state. The various indicators denote:

LED	Description
Green	On: device is ready for operation Flashing: IO-Link communication active
Blue	On: Write/read attempt being performed
Yellow	On: Write/read attempt was successful
Red	Flashing: IO-Link communication interrupted

3.4 Electrical Connection

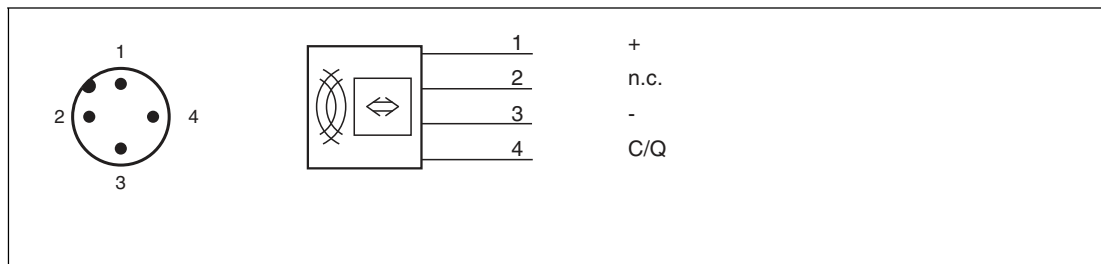

Pin 1	+24 V
Pin 2	Not connected
Pin 3	0 V
Pin 4	C/Q

The RFID read/write station is connected to an IO-Link master via a point-to-point connection. According to the IO-Link installation instructions, the length of the connection line should not exceed 20 meters. The RFID read/write station is supplied with power via the IO-Link master. For technical details, refer to the product data sheet.

3.5 IO-Link Interface Properties

IO-Link protocol:	V1.1
COM mode:	COM 3
MIN cycle time:	4 ms
Process data length:	32 byte input data / 32 byte output data
SIO mode:	Not supported
Port type:	Type A
Device ID:	0x400101
Vendor ID:	0x01

3.6 Accessories

You can connect the RFID read/write stations to any IO-Link master, as long as it supports IO-Link standard V1.1. Below are some of the available IO-Link masters from Pepperl+Fuchs:

Order designation	Description
IO-Link-Master02 USB	IO-Link master with USB interface for connecting to higher-level devices (for example PC)
ICE1-8IOL-G60L-V1D	Ethernet IO-Link module with 8 IO-Link ports for connection to a higher-level system via Profinet and EthernetIP

The RFID read/write station can access any read/write tag that is compliant with the standard ISO15693. An overview of possible read/write tags is listed in the table in Chapter 6. The following read/write tags from Pepperl+Fuchs can be used, for example:

- IQC21-16 50pcs
- IQC21-30 25pcs
- IQC21-50 25pcs
- IQC33-30 25pcs
- IQC33-50 25pcs
- IQC22-C1

To connect the RFID read/write station to an IO-Link master, you can use unshielded, three- or four-wire cables with an M12 plug with a maximum length of 20 m. For example, you can use the following connection cables from Pepperl+Fuchs:

- V1-G-2M-PUR-V1-W
- V1-G-5M-PUR-V1-W
- V1-G-10M-PUR-V1-W
- V1-G-20M-PUR-V1-W

You can find further suitable accessories on our website <http://www.pepperl-fuchs.com>.



Note!

Enter the order designation of your RFID read/write station in the product search. The product detail page contains a list of the related products.



4 Installation

4.1 Storage and Transportation

Keep the original packaging. Always store and transport the device in the original packaging.

Store the device in a clean and dry environment. The permitted ambient conditions must be considered, see datasheet.

4.2 Unpacking

Check the product for damage while unpacking. In the event of damage to the product, inform the post office or parcel service and notify the supplier.

Retain the original packaging in case you have to store or ship the device again at a later date.

Should you have any questions, please contact Pepperl+Fuchs.

4.3 Mounting and Connecting the Read/Write Station



Note!

The RFID read/write station is intended for mounting in indoor spaces only.

Mount the RFID read/write station on a level surface.



Warning!

Processes started in an uncontrolled manner jeopardize the plant

Before commissioning, ensure that there are no risks involved in using the device that may endanger the plant.



Caution!

Hot surfaces

Risk of burns when handling the read/write station! Allow the device to cool for at least half an hour after it has been shut down before touching the device.

Attach read/write station IQT1-F61-IO-V1 with two screws and IQT1-FP-IO-V1 with four screws that are inserted into the housing through the mounting holes provided.

Attach read/write station IQT1-18GM-IO-V1 using suitable mounting material, for example nuts or mounting aids.



Minimum Distances

For flush-mounting in metal surfaces, a lateral minimum distance X to metal must be observed.

For flush-mounting in metal, a protrusion Y above the mounting surface must be observed.

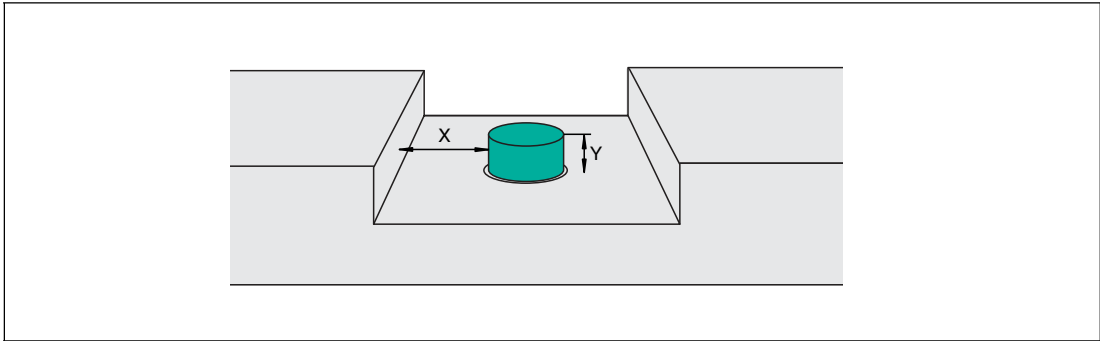

Read/write station	X	Y
IQT1-18GM-IO-V1	50 mm	16 mm
IQT1-F61-IO-V1	50 mm	12 mm
IQT1-FP-IO-V1	50 mm	40 mm

When mounting several RFID read/write stations next to each other, a minimum distance Z must be observed. This distance prevents the read/write heads from interfering with each other.

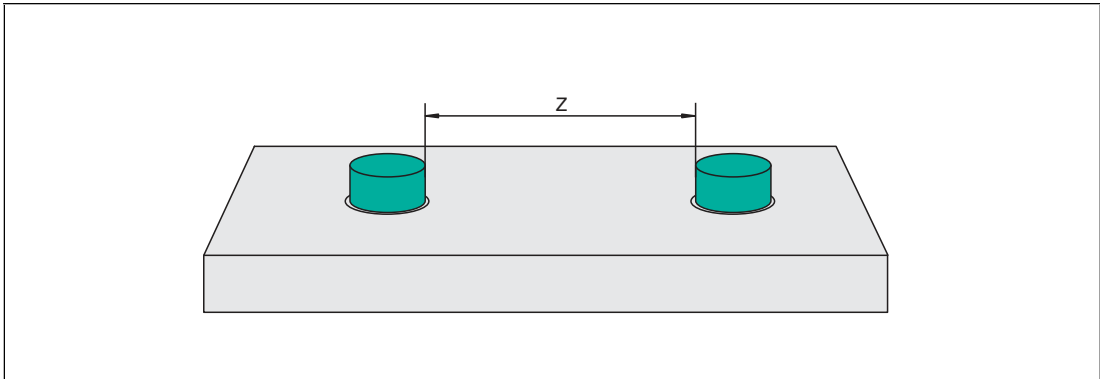

Read/write station	Z
IQT1-18GM-IO-V1	80 mm
IQT1-F61-IO-V1	150 mm
IQT1-FP-IO-V1	150 mm

5 Operation

5.1 Definitions

Notation of Number Formats

The following documentation uses different number formats. To distinguish between them, numbers are indicated in different ways.

1. Decimal numbers are shown without additional identification.

Example: 1234

2. Hexadecimal numbers are designated by a prefix "0x."

Example: 0x04 for the value 4

Abbreviations and Terminology

COM mode	The IO-Link data transfer rate
Read/write tag	Mobile data memory with user data and unique number
Device ID	Identification number of the device
Easy Mode	Protocol for simple data access of the RFID station IQT1-...-IO-V1; no function block required
Expert Mode	Protocol for high-performance data access of the RFID read/write station IQT1-...-IO-V1; the use of a function block is required
Read-only code	Unique and unchangeable number of a read/write tag; 8 bytes long
IODD	IO Device Description; file with information about IO-Link parameters of an IO-Link-enabled device
IO-Link	Communication system for the connection of intelligent sensors and actuators via point-to-point communication
IO-Link master	Interface to higher-level control; controls the communication to connected IO-Link devices
IO-Link device	Intelligent sensor or actuator for connecting to an IO-Link master; has device-specific IO-Link parameters
IO-Link Parameters	Device-specific information about an IO-Link device; parameters are stored in an IODD; acyclic change of the parameters
IO-Link protocol	Version of the supported IO-Link communication; V1.0 or V1.1
IQC	Pepperl+Fuchs-specific designation of a 13.56 MHz read/write tag
ISO/IEC 15693	Standard for data transfer for a 13.56 MHz RFID system
ISDU	Indexed Service Data Unit
PACTware	Parameterization software for access to IO-Link parameters
Port type	Type of IO-Link port
RFID read/write station	RFID read/write head with integrated IO-Link interface for contactless data transfer
SIO mode	Standard IO mode; mode for conventional signal transmission without IO-Link data
PLC	Programmable logic controller; device for control of a machine or plant
Vendor ID	Identification number of the device manufacturer, Pepperl+Fuchs: 0x01

5.2 Read/Write Tags 13,56 MHz ISO15693

The read/write tags of an RFID system with 13.56 MHz offer significantly quicker access to the data than a comparable RFID system based on an operating frequency of 125 kHz. The 13.56 MHz system is standardized through ISO15693. A great variety of read/write tags from different manufacturers using different RFID chips is supported.

Parameterization of the associated tag type is recommended to set the RFID read/write station to the tag being used. On delivery of the RFID read/write station IQT1-...-IO-V1, tag type 20 is preset. This setting guarantees access to the read-only code of ISO15693-compliant read/write tags. When using "Easy Mode," the tag type is set via the IO-Link parameter 201 "Tag type." If "Expert Mode" is enabled, the tag type is set through a command via the process image. The following table shows the tag types specified and recommend for the RFID station IQT1-...-IO-V1.

13.56 MHz/ISO 15693 Tag Types

Pepperl+Fuchs designation	Chip type	Manufacturer	Length of read-only code [byte]	Size of read/write memory [byte]	Size of memory block [byte]
IQC21	I-Code SLI(X)	NXP	8	112	4
IQC22	Tag-it HF-I Plus	Texas Instruments	8	256	4
IQC23	my-D SRF55V02P	Infinion	8	224	4
IQC24	my-D SRF55V10P	Infinion	8	992	4
IQC27	EM4135	EM Microelectronic	8	288	8
IQC31	Tag-it HF-I Standard	Texas Instruments	8	32	4
IQC32	Tag-it HF-I Pro	Texas Instruments	8	32	4
IQC33 ¹	FRAM MB89R118	Fujitsu	8	2000	8
IQC34	FRAM MB89R119	Fujitsu	8	232	4
IQC35	I-Code SLI-S	NXP	8	256	4
IQC36	I-Code SLI-L	NXP	8	32	4
IQC37 ²	FRAM MB89R112	Fujitsu	8	8192	32

Table 5.1 13.56 MHz tag types in accordance with ISO 15693

1.Exception: Block size = 8 bytes
'Number of Bytes' must be a multiple of 8

2.Exception: Block size = 32 bytes
'Number of Bytes' must be a multiple of 32

All ISO15693-compliant read/write tags have a unique 8 byte read-only code. The read-only code is determined by the chip manufacturer. The user can only read it and it cannot be changed. In addition, the read/write tags have a memory for user data. This can be written with application-specific data and read. The size of the memory for the user data differs according to the tag type.

The memory is divided into blocks with a length of 4 bytes. There are also exceptions with a block length of 8 bytes or 32 bytes. As a result of the block length of 32 bytes, Easy Mode does not support the tag type IQC37.

The read and write commands use the "Number of bytes" and "Start address" parameters. This defines how many bytes are accessed in the memory of the user data and from which memory address this starts. If the tag type used, for example, has a block length of 4 bytes, the values of the "Number of bytes" and "Start address" parameters must be a multiple of 4. In the case of a block length of 8 or 32 bytes, they are multiples of 8 or 32.

5.3 Easy Mode

The RFID read/write station uses the "Easy Mode" protocol on the basis of IO-Link for data transfer to a higher-level system. If this protocol is used, the RFID read/write station can be put into operation without an additional function block on a control system. This makes it easier to commission the read/write station.

When "Easy Mode" is used, there is a distinction between parameter and process data. The parameter data is IO-Link parameters being transferred acyclically. This is data for the configuration of the read/write commands. The process data is transferred cyclically. The process data is divided into input and output data. It has a length of 32 bytes and contains the control values for the execution of the read and write commands and the associated values.

The IO-Link parameters for setting the RFID read/write station are defined by a device-specific IODD file. The IO-Link parameters are set using suitable configuration software. During this process, the IO-Link parameters are saved in a non-volatile memory in the RFID read/write station.

5.4 Command Overview

The Easy Mode supports the following read and write commands:

Command	Description
Read the read-only code (UID)	Read-out of the 8 byte read-only code; no setting of the "Number of bytes" or "Start Address" parameters required
Read the user memory	Read-out of user data; setting of the "Number of bytes" and "Start Address" parameters is required
Write the user memory	Writing of user data; setting of the "Number of bytes" and "Start Address" parameters is required
Auto-start	Automatic execution of a read task for read-only code or user data after device start

5.4.1 Easy Mode Data Structure

IO-Link Parameters IQT1-...-IO-V1

The following IO-Link parameters are available for the RFID read/write station in Easy Mode. Access to the parameter data is acyclical. Each parameter is uniquely identified through its associated ISDU index.

"Tag Type" (ISDU Index 201)

Set the tag type to be used. Tag type 20 is preset on delivery. This enables the read-only memory of all ISO15693-compliant read/write tags to be read. The station adjusts to the tag type of the read/write tag that was read first. The setting is stored in the non-volatile memory of the RFID read/write station. For a list of supported tag types see chapter 5.2.

Value range: See table "13.56 MHz/ISO 15693 Tag Types" on page 17
 Default value: 20 (automatic setting)
 Data format: Decimal

"Mode" (ISDU Index 203)

This parameter determines the operating mode of the RFID read/write station. Easy Mode is selected as the operating mode on delivery.

Value range: Easy Mode (0x80), Expert Mode (0x00)
 Default value: Easy Mode (0x80)

"Read Task" (ISDU Index 204)

This parameter set consists of several individual parameters which define read access to a read/write tag.

Auto-Start (Subindex 4)

The auto-start function allows for automatic execution of a previously defined read access to a read/write tag without additional activation via the process data. The command is started independently through the RFID read/write station when it is switched on. This function is activated on delivery.

Value range: Off; On
Default value: On

Memory Area (Subindex 1)

This parameter determines whether the read access is for the usable data range (user data) or the read-only code (UID).

Value range: User data; read-only code
Default value: User data

Number of Bytes (Subindex 2)

Number of bytes to be read when accessing user data. On delivery, access to 8 bytes of user data is set. The adjustable number of bytes depends on the block length of the read/write tag. If the memory of the read/write tag has a block length of 4 bytes (for example IQC21/22/24), the number is always a multiple of 4. If the block length is 8 bytes (for example IQC33), the number is a multiple of 8 bytes. In Easy Mode, a maximum of 28 bytes of usable data can be accessed.

Value range: 4, 8, 12, 16, 20, 24, 28
Default value: 8
Data format: Decimal

Start Address (Subindex 3)

Specifies the start address from which read access in the user data range begins. The adjustable value depends on the block length of the read/write tag. If the memory of the read/write tag has a block length of 4 bytes (for example IQC21/22/24), the number is always a multiple of 4. If the block length is 8 bytes (for example IQC33), the number is a multiple of 8 bytes. The maximum value of the address depends on the memory size of the read/write tag.

Value range: 0x0000; 0x0004; 0x0008; 0x000C;
Default value: 0x0000
Data format: Hexadecimal

"Write Task" (ISDU Index 205)

This parameter set consists of several individual parameters which determine write access to a read/write tag.

Memory Area (Subindex 1)

This parameter specifies that there is write access to the user data. Write access to a different data range is not possible for read/write tags in accordance with ISO15693.

Value range: User data
Default value: User data



Number of Bytes (Subindex 2)

Number of bytes to be written on the read/write tag through the write task. On delivery, 8 bytes of user data can be written. The adjustable number of bytes depends on the block length of the read/write tag. If the memory of the read/write tag has a block length of 4 bytes (for example IQC21/22/24), the number is always a multiple of 4. If the block length is 8 bytes (for example IQC33), the number is a multiple of 8 bytes. In Easy Mode, a maximum of 28 bytes of usable data can be written per write task.

Value range: 4, 8, 12, 16, 20, 24, 28
 Default value: 8
 Data format: Decimal

Start Address (Subindex 3)

Specifies the start address from which write access to the user data begins. The adjustable value depends on the block length of the read/write tag. If the memory of the read/write tag has a block length of 4 bytes (for example IQC21/22/24), the number is always a multiple of 4. If the block length is 8 bytes (for example IQC33), the number is a multiple of 8 bytes. The maximum value of the address depends on the memory size of the read/write tag that is being used.

Value range: 0x0000; 0x0004; 0x0008; 0x000C;
 Default value: 0x0000
 Data format: Hexadecimal

5.4.2 IO-Link Process Data

The process data of the RFID read/write station is exchanged cyclically between a higher-level system (for example a PLC) and the RFID read/write station. It is important to distinguish between the input process data and the output process data. The process data of the outputs is transferred from the control system in the direction of the RFID read/write station. The data from the RFID read/write station to the control system represents the input process data. Both process data fields have a length of 32 bytes each.

Output Process Data (PLC -> IQT1-...-IO-V1)

Byte	Content
0	0 0 0 0 0 0 0 Write Read
1	0x00
2	0x00
3	0x00
4	0x00 (Optional: Write user data)
...	0x00 (Optional: Write user data)
31	0x00 (Optional: Write user data)

Table 5.2

- Byte 0** This byte contains the control bits for the start of a read task or write task. If the auto-start function is activated, the control bits have no effect.
Read: When this bit is set (TRUE), a read task starts according to the configuration of the IO-Link parameters. The read task runs continuously. The bit must be reset to cancel the read task (FALSE).
Write: When this bit is set (TRUE), a write task starts according to the configuration of the IO-Link parameters. The write task runs continuously. To cancel the write task, the bit must be reset (FALSE). It is important to note that both bits are not set simultaneously. The remaining bits are of no significance.
- Byte 1/2/3** These bytes are in not used in Easy Mode and must therefore be set with the value 0x00.
- Byte 4...31** When a read task is being executed, these bytes have no significance and are set with the value 0x00. When a write task is being executed, the user data to be written on the read/write tag is stored in this area.

Input Process Data (IQT1-...-IO-V1 -> PLC)

Byte	Content							
0	0	0	0	0	Error	Task active	Write successful	Read successful
1	Length of data / length of error information							
2	0x00							
3	0x00							
4	Read data / error code							
5	Read data / error information							
...	Read data / error information							
31	Read data / error information							

Table 5.3

- Byte 0** This byte contains the control bits to indicate the status of the execution of the read or write task.
Read successful: This bit indicates successful reading of data from a read/write tag. If a read/write tag enters the detection zone and the data was read successfully, this bit is set. The bit remains set while the read/write tag is within the detection zone. It is reset as soon as the read/write tag has left this area.
Write successful: This bit indicates successful writing of data to a read/write tag. If a read/write tag enters the detection zone and the data was written successfully, this bit is set. The bit remains set while the read/write tag is within the detection zone. It is reset as soon as the read/write tag has left this area.
Task active: This bit is set for the duration of the execution of a read or write task. After completion of the task, this bit is reset again.
Error: If an error occurs during the execution of a read or write task or if the setting of an IO-Link parameter is not correct, this bit will signal this accordingly. At the same time, additional error information in the form of an error code and an error description is located in the process data. For a detailed description of the error see chapter 6.2.
- Byte 1** This byte contains the number of read bytes. If a read/write tag enters the detection zone and the data was read successfully (Read successful = TRUE), this byte indicates the length of the read data. If an error occurs during the execution of a task (Error = TRUE), the byte contains a length specification for the error information.



- Byte 2/3** These bytes are not used in Easy Mode. The bytes must therefore be set with the value 0x00.
- Byte 4...31** These bytes contain the read data that was read from the read/write tag during a successful execution of a read task. They may also contain a read-only code or user data. As soon as an error occurs during task execution (Error = TRUE), an error code for the event will be located in byte 4. Starting with byte 5, further error information is transferred in plain text. This enables the cause of the error to be determined.

If the IO-Link parameters are changed during the execution of a read or write task, the "Task active" bit is set again. Depending on the task, this also impacts the "Read successful" and "Write successful" bits.

5.4.3 Flow Diagrams

Read Task with Auto-Start Function

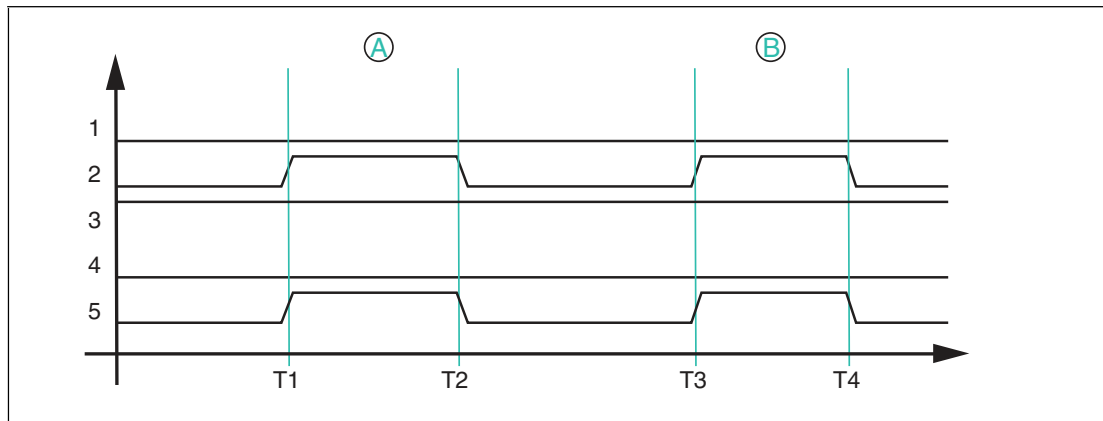

- 1 Read
- 2 Read successful
- 3 Task active
- 4 Task
- 5 Data (input)

If the auto-start function is used, read access runs continuously; the "Task active" bit of the input process data is set permanently.

T1: Read/write tag A enters the detection zone; "Read successful" is set to TRUE and the read data is located in the input field of the process data

T2: Read/write tag A leaves the detection zone; "Read successful" is reset to FALSE; the area with the previously read data is filled with 0x00

T3: Read/write tag B enters the detection zone; identical behavior to T1

T4: Read/write tag B leaves the detection zone; identical behavior to T2

Read Task without Auto-Start Function

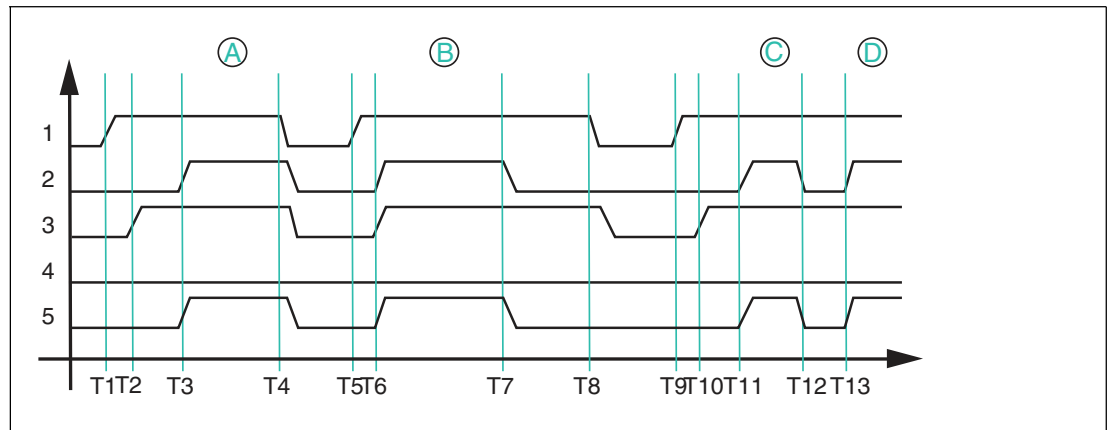

- 1 Read
- 2 Read successful
- 3 Task active
- 4 Task
- 5 Data (input)

If the auto-start function is not used, the read task is started with the "Read" bit. The read task is performed until the "Read" bit is reset to FALSE.

T1: Starting the read task by setting the "Read" bit to TRUE

T2: Read task is executed and signaled through the "Task active" bit ("Task active" = TRUE)

T3: Read/write tag A enters the detection zone; "Read successful" is set to TRUE and the read data is located in the input field of the process data

T4: Read task is canceled by resetting the "Read" bit to FALSE while the read/write tag is located in the detection zone; the "Task active" bit and the "Read successful" bit are set to FALSE and the process data is filled with 0x00

T5: Start of read task by setting the "Read" bit to TRUE; at the time of the start, a read/write tag B is already located in the detection zone

T6: Read task is executed ("Task active" = TRUE) and the data is read successfully ("Read successful" = TRUE); the read data is located in the input field of the process data

T7: Read/write tag leaves the detection zone ("Read successful" = FALSE); the area of the input field with the read process data is set to the value 0x00

T8: Cancellation of the read task ("Read" = FALSE); the "Task active" bit is reset

T9: Start of read task by setting the "Read" bit to TRUE; at the time of the start, no read/write tag is located in the detection zone; read task remains permanently active

T10: Read task is executed ("Task active" = TRUE)

T11: Read/write tag C enters the detection zone and the data is read ("Read successful" = TRUE); read data is located in the input field of the process data

T12: Read/write tag C leaves the detection zone ("Read successful" = FALSE)

T13: Read/write tag D enters the detection area

Write Task

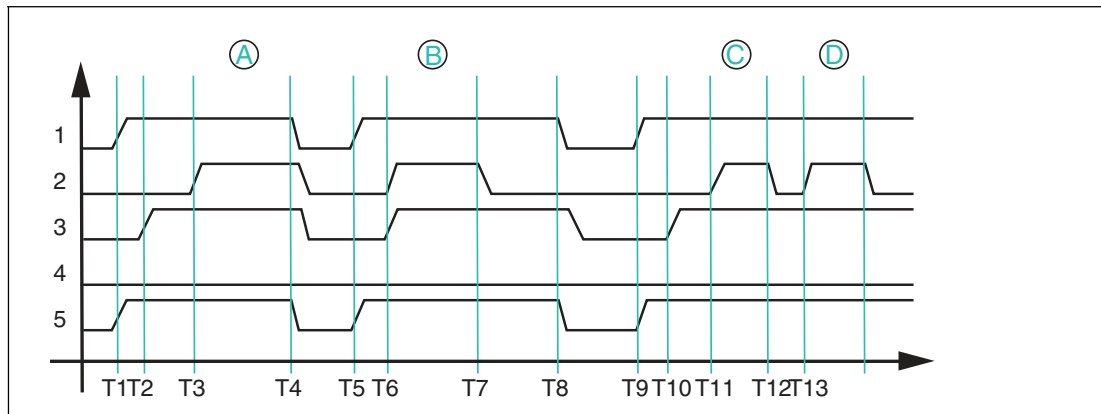

- 1 Write
- 2 Write successful
- 3 Task active
- 4 Task
- 5 Data (output)

A write task cannot be executed via the auto-start function. To start a write task, set the "Write" bit to TRUE.

T1: Start the write task by setting the "Write" bit to TRUE; at the same time, the usable data to be written on the read/write tag is transferred to the output field of the process data

T2: Write task is active ("Task active" = TRUE), and no read/write tag is located in the detection zone ("Write successful" = FALSE)

T3: Read/write tag A enters the detection zone and the data is written successfully ("Write successful" = TRUE)

T4: Cancellation of the write task by resetting the "Write" bit to FALSE; the "Task active" bit is reset to FALSE and the usable data is reset by the user to the value 0x00

T5: Start of write task by setting the "Write" bit to TRUE and at the same time transferring the data to be written to the output field of the process data; at the time of the start, read/write tag B is located in the detection zone

T6: The write task is active ("Task active" = TRUE) and read/write tag B is written successfully ("Write successful" = TRUE)

T7: Read/write tag B leaves the detection zone ("Write successful" = FALSE); write task remains active ("Task active" = TRUE)

T8: Cancellation of the write task by resetting the "Write" bit to FALSE; the "Task active" bit is reset to FALSE and the user resets the usable data to the value 0x00

T9: Start of the write task by setting the "Write" bit to TRUE; at the same time, the usable data to be written on the read/write tag is transferred to the output of the process data

T10: Write task is active ("Task active" = TRUE) and no read/write tag is located in the detection zone ("Write successful" = FALSE)

T11: Read/write tag C enters the detection zone and the data is successfully written ("Write successful" = TRUE); write task is still active ("Task active" = TRUE)

T12: Read/write tag C leaves the detection zone ("Write successful" = FALSE); write task is still active ("Task active" = TRUE)

T13: Read/write tag D enters the detection zone and the data is successfully written ("Write successful" = TRUE); write task is still active ("Task active" = TRUE)

Task State

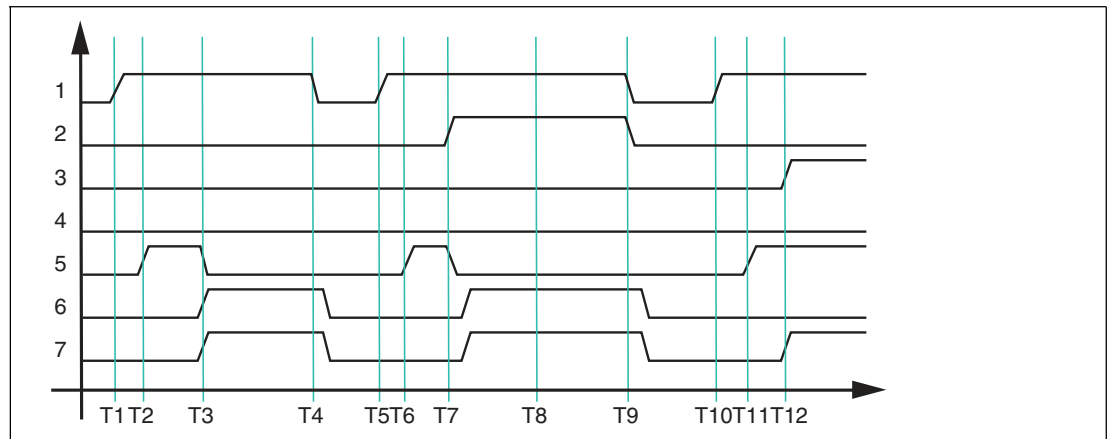

- 1 Read
- 2 Write
- 3 Read successful
- 4 Write successful
- 5 Task active
- 6 Task
- 7 Data (input)

If an error occurs during execution of a read or write task, this status will be signaled via the "Task" bit. A error message is transferred in the area of the input process data at the same time.

T1: Start of read task by setting the "Read" bit to TRUE

T2: Read task is active and is being executed ("Task active" = TRUE)

T3: An IQC33 read/write tag enters the detection zone and the "Task" bit is set to TRUE. The "Task active" bit is also reset to FALSE and at the same time the error code 0x04 and the text "invalid command" are entered in the input field of the process data. This indicates that the read task set by the IO-Link parameters is not suitable for the properties of the IQC33 read/write tag. This is due to the number of the bytes to be read. Multiples of 8 are required as the number of bytes to access the IQC33. But in this example, the value is set to 4. This must be corrected within the IO-Link parameter set for the "Read task" (Index 204).

T4: Cancellation of the read task by resetting the "Read" bit to FALSE; the "Task" bit of the error message in the process data remains unchanged

T5: Start of a new read task by setting the "Read" bit to TRUE; at the same time, the "Task" bit is reset to FALSE and the error message in the input data is deleted

T6: Read task is active and being executed ("Task active" = TRUE)

T7: A write task is also started by setting the "Write" bit to TRUE. The "Task" bit is set and "Task active" is reset to FALSE. A error message with the error code 0x04 and the text "read AND write" is transferred to the input field of the process data. This indicates that a read and a write task have been activated simultaneously. This is not permitted for the RFID read/write station.

T8: The error state remains active ("Task" = TRUE), because the "Read" and "Write" bits are set

T9: The "Read" and "Write" bits are reset to FALSE

T10: Start of the read task by setting the "Read" bit to TRUE; at the same time, the "Task" bit is reset to FALSE and the error message in the input data is deleted

T11: Read task is active and being executed ("Task active" = TRUE)

T12: A read/write tag enters the detection zone and is read successfully ("Read successful"=TRUE)

5.4.4 Timing

Easy Mode does not use a complex handshake procedure for the data transfer of the RFID read/write station IQT1-...-IO-V1. Instead, the messages are set in the input field of the process data (IQT1 -> PLC) and remain there for a defined hold time. Within this hold time, no changes can be made to the input data field on the part of the RFID read/write station.

The IO-Link cycle time of the RFID read/write station is at least 4 ms. Each telegram remains unchanged in the input field of the process data for at least ten IO-Link cycles. This results in a holding time of at least 40 ms.

If a new message is generated by the RFID read/write station within the hold time of 40 ms (for example a new read/write tag is read or a read/write tag leaves the detection range), this message is only set in the input field of the process data once the hold time of 40 ms has expired. If no new message occurs within the hold time, the data in the input field of the process data remains unchanged.

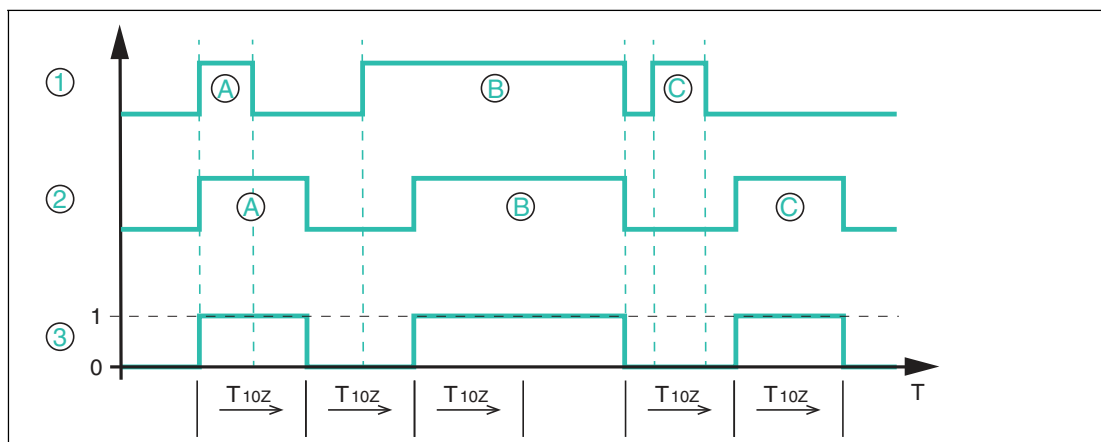

- ① Read/write tag is in field
- ② Data
- ③ Read successful

The image above shows the principle of the chronological sequence of the data transfer depending on the presence of a read/write tag within the detection range of the RFID read/write station IQT1-...-IO-V1.

" T_{10Z} " corresponds to the holding time of ten cycles of the IO-Link cycle time (4 ms) of the RFID read/write station. It must be at least 40 ms.

The RFID read/write station is activated through the auto-start function or through the "Read" bit. As a result, a read task is run permanently at the station.

At the beginning, read/write tag A enters the detection range of the read/write station and the "Read successful" bit in the input field of the process data changes the signal state from 0 to 1. The read/write tag stays in the detection range for less than 40 ms and exits it shortly after entering. The input field of the process data with the information about read/write tag A is retained for the time " T_{10Z} " (= 40 ms). The input field of the process data is only updated again once this period has expired and now contains the information "Read successful" = FALSE (no read/write tag) and signals that the read/write tag has left the detection range. This message also remains in the input field of the process data for the hold time of " T_{10Z} ".

Read/write tag B enters the detection range before the end of the hold time of the previous message. The input field of the process data is only updated once the hold time of 40 ms has expired, and the "Read successful" bit then changes the signal state from 0 to 1. At the same time, the read data is set in the input field of the process data. Read/write tag B has a dwell time of more than 40 ms ($> T_{10Z}$) within the detection range of the RFID read/write station. For this time period, the input field of the process data remains unchanged and the "Read successful" bit continues to have signal state 1.

Read/write tag B leaves the detection range and the signal state of the "Read successful" bit changes from 1 to 0 in the input field of the process data. Before the end of the hold time "T_{10Z}," read/write tag C enters the detection range. The input field of the process data remains unchanged for the duration of the hold time and changes the signal state of "Read successful" from 0 to 1 after the end of "T_{10Z}." As a result, the presence of read/write tag C is signaled and the read data of this tag is transferred.

Read/write tag C exits the detection range before the end of the hold time "T_{10Z}." After the hold time of the previous information has expired (read/write tag B has left the detection range), the process image is modified accordingly. The signal state of "Read successful" changes from 0 to 1.

5.5 Easy Mode with PACTware

In this section, you will learn how to put the RFID read/write station into operation with the help of the IO-Link master "IO-Link Master02-USB." Connect the RFID read/write station to the IO-Link master and then connect this to a PC using a USB cable. The system is operated with the PACTware software, which you can download on the Pepperl+Fuchs homepage. To integrate the IODD files into PACTware on your PC, you can use the IODD Interpreter DTM software tool available on the P+F homepage.

First, install the two software packages on your PC. Then install the IO-Link USB master DTM 2.0 driver, which is also available on the P+F homepage. Then import the IODD file for the RFID read/write station with the IODD DTM Configurator program.

The driver for the IO-Link USB master and the IODD file for the RFID read/write station are available on the corresponding product page.



PACTware

1. Start PACTware. Add the IO-Link master.

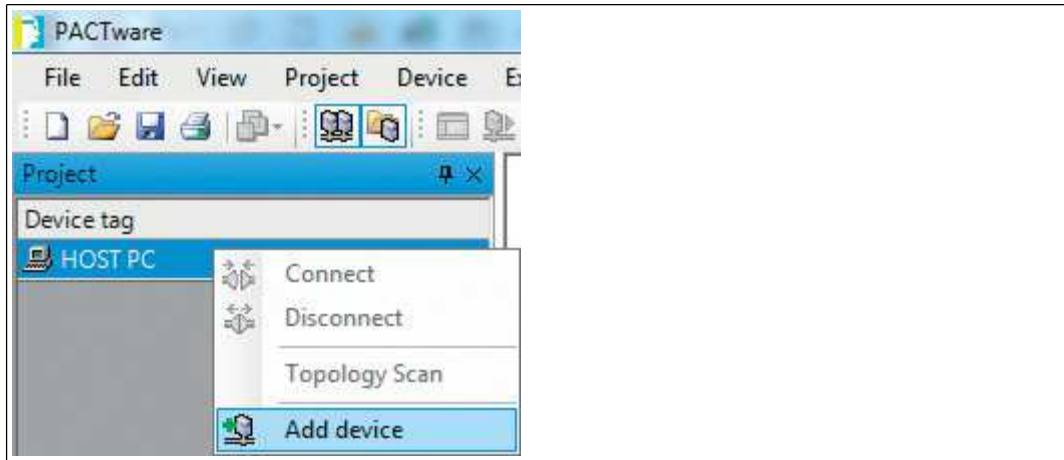

Figure 5.1

2. Connect to the IO-Link master.

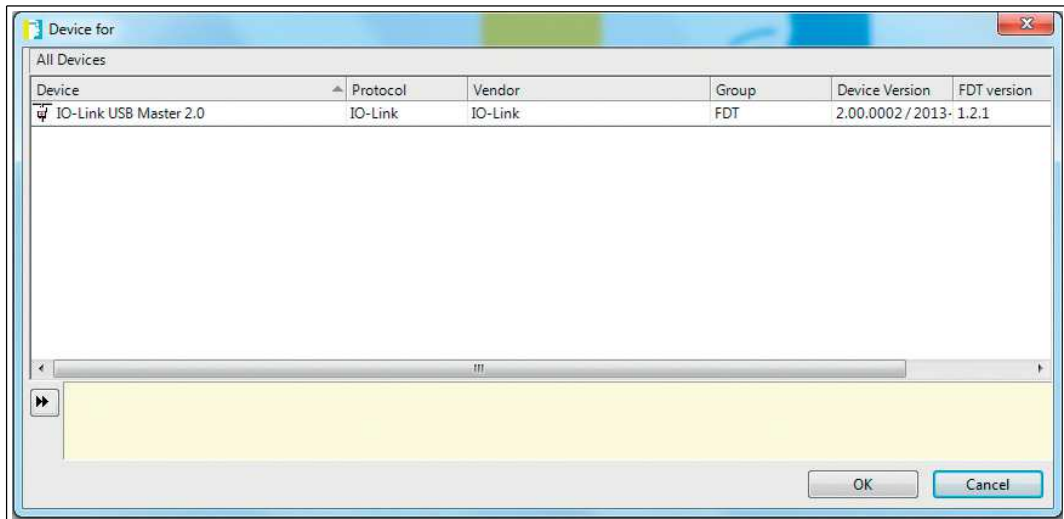

Figure 5.2

3. Now add the RFID read/write station in the same way.

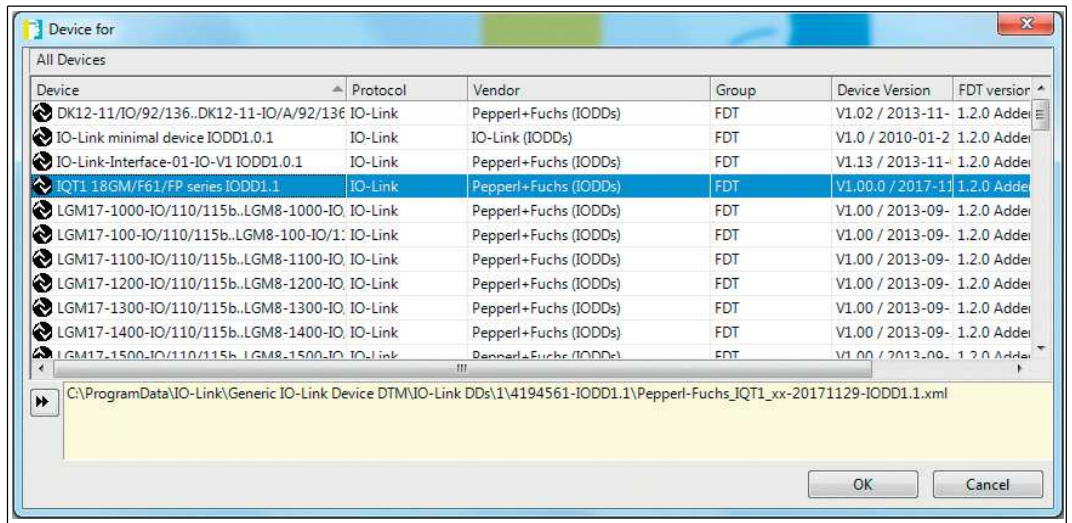

Figure 5.3

4. Establish the connection to the RFID read/write station.



Figure 5.4

5. Select the Online Parameterization menu option.

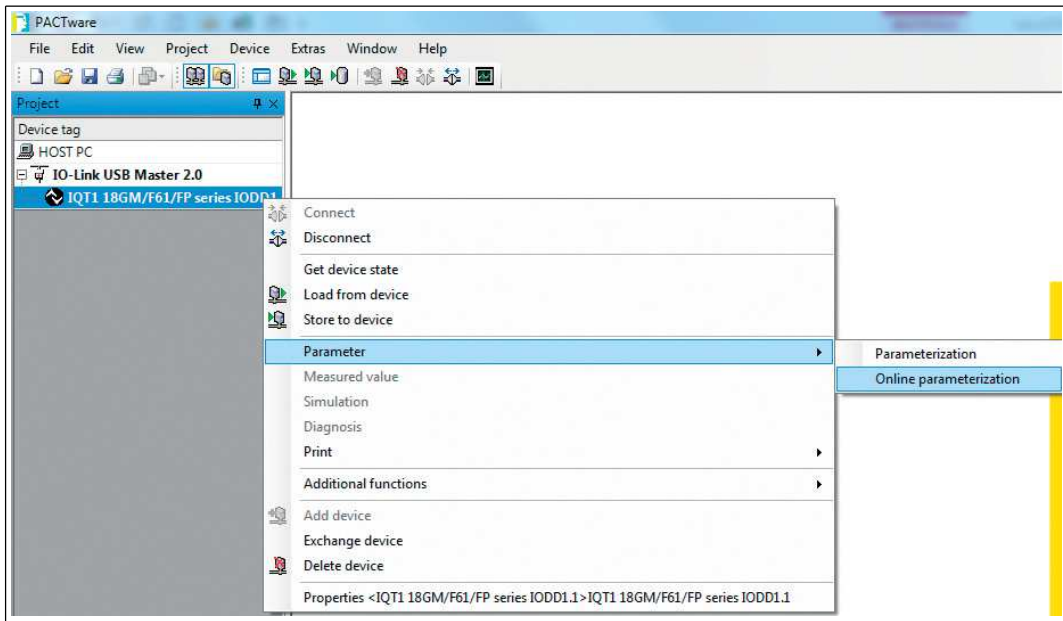

Figure 5.5

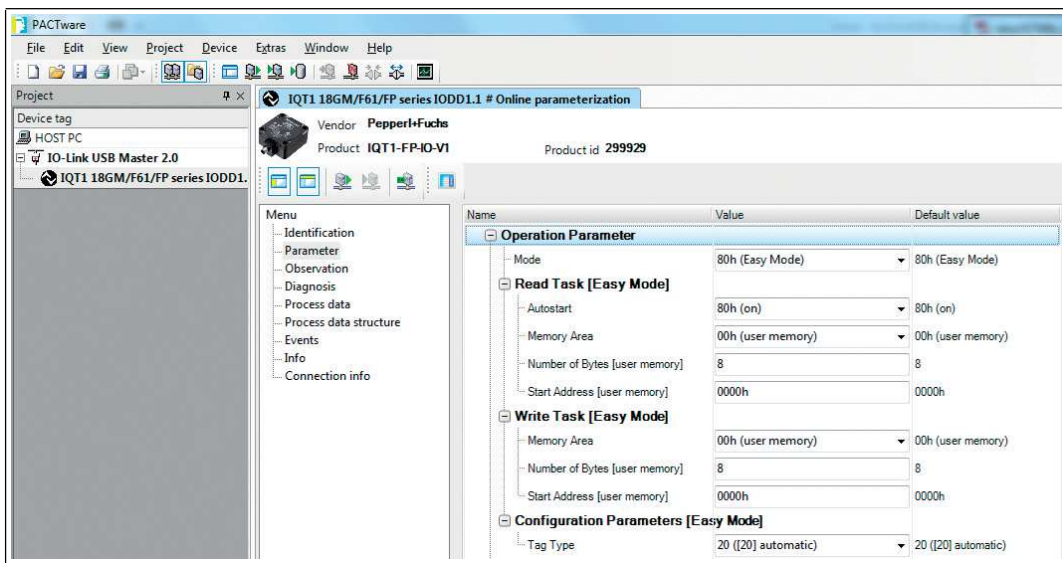

Figure 5.6

- The RFID read/write station automatically begins reading 8 bytes of user data from start address 0. The values are in the input process data.

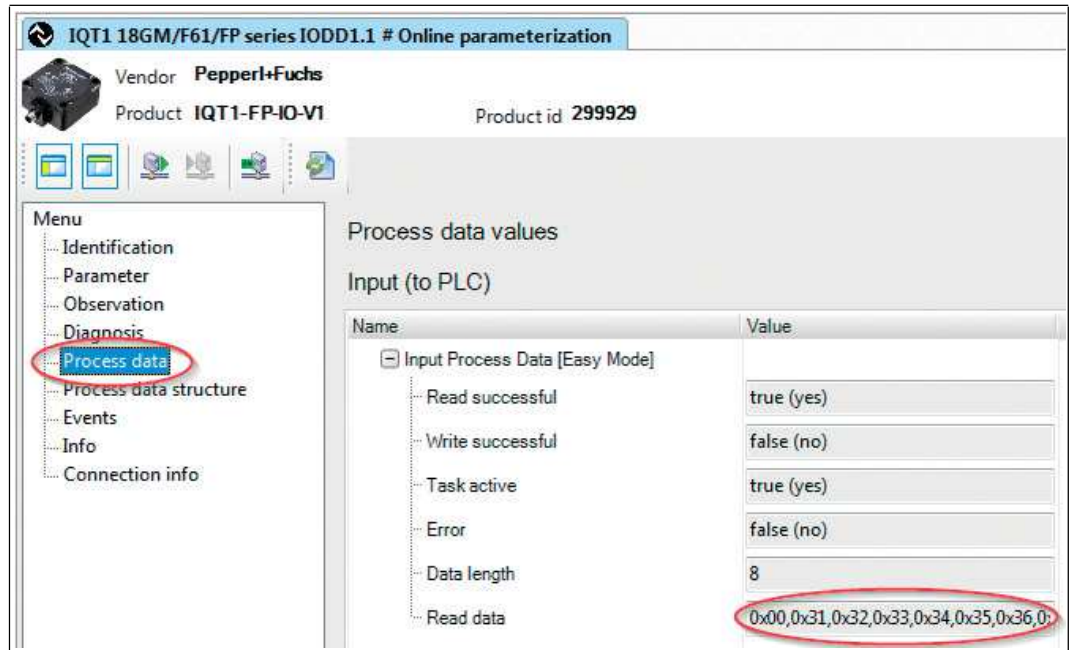

Figure 5.7

5.6 Expert Mode

The Expert Mode allows for higher-performance data access for larger amounts of data using a handshake procedure. The use of a function block is required. You can download the function block and instructions on the corresponding product page of the RFID read/write station. Enter the type designation for your read/write station in the product search.

6 Appendix

6.1 IO-Link Parameters

"Tag Type" IO-Link Parameter – ISDU Index 201

Index	Subindex	Length [byte]	Value (hex)	Access	Meaning
201	0	1	0x14	Read/write	Automatic setting for the read/write tag; read-only code of each ISO 15693-compliant read/write tag readable; factory setting
			0x15	Read/write	IQC21 – "I-Code SLI"
			0x16	Read/write	IQC22 – "Tag-it HF-I Plus"
			0x17	Read/write	IQC23 – "My d SRF55V02P"
			0x18	Read/write	IQC24 – "My d SRF55V10P"
			0x1B	Read/write	IQC27 – "EM4135"
			0x2F	Read/write	IQC31 – "Tag-it HF-I Standard"
			0x20	Read/write	IQC32 – "Tag-it HF-I Pro"
			0x21	Read/write	IQC33 – "MB89R118"
			0x22	Read/write	IQC34 – "MB89R119"
			0x23	Read/write	IQC35 – "I-Code SLI-S"
0x24	Read/write	IQC36 – "I-Code SLI-L"			

Table 6.1

"Mode" IO-Link Parameter – ISDU Index 203

Index	Subindex	Length [byte]	Value (hex)	Access	Meaning
203	0	1	0x80	Read/write	Easy Mode selected; factory setting; allows simplified data access to 28 bytes of usable data or read-only code
			0x00	Read/write	Expert Mode selected; setting for the transfer of large amounts of data via handshake procedure; use of a function component required

Table 6.2

"Read Task" IO-Link Parameter – ISDU Index 204

Index	Subindex	Length [byte]	Value (hex)	Access	Meaning
204	1	1	0x00	Read/write	Read access to user data (usable data)
			0x80	Read/write	Read access to read-only code
204	2	1	0x00 ... 0x1C	Read/write	Number of bytes of user data to be read; value must be a multiple of 4; when using a read/write tag with a block length of 8 bytes, a multiple of 8 must be set

Index	Subindex	Length [byte]	Value (hex)	Access	Meaning
204	3	2	0x0000 0xFFFF F	Read/write	Start address on read/write tag with access to user data (usable data); value must be a multiple of 4; when using a read/write tag with a block length of 8 bytes, a multiple of 8 must be set
204	4	1	0x80	Read/write	Auto-start function on; the auto-start function can activate a permanent read execution; additional activation is then no longer necessary
			0x00	Read/write	Auto-start function off; read and write must be started by triggering the "Read" or "Write" bit in the output data field

Table 6.3

"Write Task" IO-Link Parameter – ISDU Index 205

Index	Subindex	Length [byte]	Value (hex)	Access	Meaning
205	1	1	0x00	Read/write	Access of write task to user data (usable data)
205	2	1	0x00 ... 0x1C	Read/write	Number of bytes of user data to be written; value must be a multiple of 4; when using a read/write tag with a block length of 8 bytes, a multiple of 8 must be set
205	3	2	0x0000 0xFFFF	Read/write	Start address on read/write tag with access to user data (usable data); value must be a multiple of 4; when using a read/write tag with a block length of 8 bytes, a multiple of 8 must be set

Table 6.4

6.2 Error Repair

Index	Description	Solution
1	No blue LED on; only the green LED flashes	Is the auto-start function active?
2	No orange LED if read/write tag is within the detection range	Is the matching tag type set? Read out the IO-Link parameter 201 and compare the result with the tag list. Does the number of bytes fit with the block length of the tag?
3	No flashing green LED	Is the IO-Link configuration of the master correct? Is the IO-Link version V1.1 supported? Is the connection cable connected correctly?
4	Byte 0 of the input data field contains 0x40	This value indicates that the Expert Mode is enabled. In this case, the value of the "Easy Mode" IO-Link parameter is 0x00. Change the "Easy Mode" IO-Link parameter to the value 0x80. The higher nibble always has the value 0x00 in Easy Mode.
5	The read/write tag IQC33 cannot be read or written	Is the number of bytes within the "Read task" or "Write task" IO-Link parameter a multiple of 8?
6	The read/write tag IQC37 cannot be read or written	The IQC37 is only supported when using the Expert Mode.
7	No change of the read data despite change of the start address	The address is counted by bytes. Please note the correct block length of the tag type: 4 or 8 bytes. The data will be changed when the address is increased by the block length.
8	After setting the tag type IQC33, "invalid command" is displayed	Set the number of bytes to 8 or a multiple thereof.
9	An unknown read/write tag cannot be read	Reset the RFID read/write station to the factory setting. Switch the execution of the read task to the read-only code: Change the "Read Task" IO-Link parameter. Can the read-only code be read? If the read-only code is readable, the read/write tag can be accessed. You may need to change the tag type; if access is not possible, the read/write tag is incompatible with ISO15693.
10	Reset to factory setting using parameter 2 does not work	After execution of a "Write" command on the IO-Link parameter 2 with the value 0x82, the supply voltage of the unit must be reset.

6.3 ASCII table

hex	dec	ASCII	hex	dec	ASCII	hex	dec	ASCII	hex	dec	ASCII
00	0	NUL	20	32	Space	40	64	@	60	96	'
01	1	SOH	21	33	!	41	65	A	61	97	a
02	2	STX	22	34	"	42	66	B	62	98	b
03	3	ETX	23	35	#	43	67	C	63	99	c
04	4	EOT	24	36	\$	44	68	D	64	100	d
05	5	ENQ	25	37	%	45	69	E	65	101	e
06	6	ACK	26	38	&	46	70	F	66	102	f
07	7	BEL	27	39	'	47	71	G	67	103	g
08	8	BS	28	40	(48	72	H	68	104	h
09	9	HT	29	41)	49	73	I	69	105	i
0A	10	LF	2A	42	*	4A	74	J	6A	106	j
0B	11	VT	2B	43	+	4B	75	K	6B	107	k
0C	12	FF	2C	44	,	4C	76	L	6C	108	l
0D	13	CR	2D	45	-	4D	77	M	6D	109	m
0E	14	SO	2E	46	.	4E	78	N	6E	110	n
0F	15	SI	2F	47	/	4F	79	O	6F	111	o
10	16	DLE	30	48	0	50	80	P	70	112	p
11	17	DC1	31	49	1	51	81	Q	71	113	q
12	18	DC2	32	50	2	52	82	R	72	114	r
13	19	DC3	33	51	3	53	83	S	73	115	s
14	20	DC4	34	52	4	54	84	T	74	116	t
15	21	NAK	35	53	5	55	85	U	75	117	u
16	22	SYN	36	54	6	56	86	V	76	118	v
17	23	ETB	37	55	7	57	87	W	77	119	w
18	24	CAN	38	56	8	58	88	X	78	120	x
19	25	EM	39	57	9	59	89	Y	79	121	y
1A	26	SUB	3A	58	:	5A	90	Z	7A	122	z
1B	27	ESC	3B	59	;	5B	91	[7B	123	{
1C	28	FS	3C	60	<	5C	92	\	7C	124	
1D	29	GS	3D	61	=	5D	93]	7D	125	}
1E	30	RS	3E	62	>	5E	94	^	7E	126	~
1F	31	US	3F	63	?	5F	95	_	7F	127	DEL

FACTORY AUTOMATION – SENSING YOUR NEEDS



Worldwide Headquarters

Pepperl+Fuchs GmbH
68307 Mannheim · Germany
Tel. +49 621 776-0
E-mail: info@de.pepperl-fuchs.com

USA Headquarters

Pepperl+Fuchs Inc.
Twinsburg, Ohio 44087 · USA
Tel. +1 330 4253555
E-mail: sales@us.pepperl-fuchs.com

Asia Pacific Headquarters

Pepperl+Fuchs Pte Ltd.
Company Registration No. 199003130E
Singapore 139942
Tel. +65 67799091
E-mail: sales@sg.pepperl-fuchs.com

www.pepperl-fuchs.com

 **PEPPERL+FUCHS**
SENSING YOUR NEEDS