

Ultrasonic double sheet monitor UDB-18GM35-3E2



Features

- Ultrasonic system for detection of single sheet, no sheet and double sheet. Also detection of pasted double sheets.
- Weights of paper from 30 g up to cartons weighing over 1200 g can be detected.
- It is also possible to detect thin metal and plastic films.
- Various materials and thicknesses are programmed in via a TEACH-IN signal.
- Automatic compensation of the operating point in the case of slowly changing ambient conditions.
- Signal output via short-circuit proof PNP switch outputs.
- Very high processing speeds are possible.

Electrical connection

Standard symbol/Connection:
Double-sheet-control

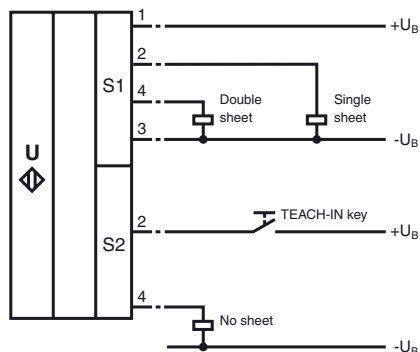

Connector V1



Dimensions

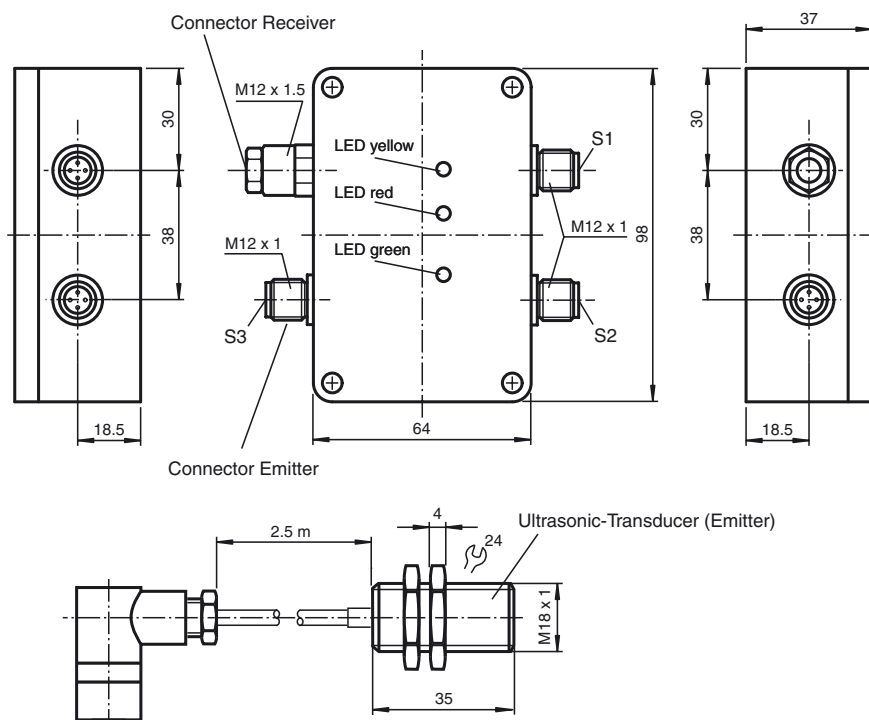

Technical data



General specifications

Transducer frequency 180 kHz

Indicators/operating means

LED green indication: single sheet detected
LED yellow indication: no sheet detected
LED red indication: double sheet or pasted double sheets detected

Electrical specifications

Operating voltage 20 ... 30 V DC, ripple 10 %_{SS}
No-load supply current I_0 < 80 mA

Input

Input type 1 pulse input for TEACH-IN
Pulse length ≥ 100 ms
Impedance ≥ 10 kOhm
Voltage 12 ... 30 V

Output

Output type 3 switch outputs pnp, NO
Rated operational current I_b 3 x 200 mA
Voltage drop U_d ≤ 2 V
Switch-on delay t_{on} ≤ 5 ms
Switch-off delay t_{off} ≤ 5 ms

Standard conformity

Standards EN 60947-5-2

Ambient conditions

Ambient temperature 0 ... 60 °C (273 ... 333 K)
Storage temperature -40 ... 70 °C (233 ... 343 K)

Mechanical specifications

Protection degree IP65
Connection emitter: V1-W connector with 2.5 m cable
receiver: 2.5 m fixed cable (not disconnectable)
S1,S2: 2 connectors V1-W, M12x1 (included with delivery)

Material

Housing Makrolon/nickel-plated brass
Mass 370 g

Notes

Description of the sensor functions

In addition to the printing industry, the ultrasonic double-sheet monitor is deployed in all situations in which the automatic distinction between single and double sheets is required in order to protect machines or avoid waste production. The double-sheet monitor is based on the ultrasonic through-beam principle. The following can be detected:

- No sheet
- Individual sheet
- Double sheet or pasted double sheet

A microprocessor system evaluates the signals. The appropriate switch outputs are set as a result of the evaluation. Changes in ambient conditions such as temperature and humidity are automatically compensated. The evaluation electronics are installed in a cuboid plastic housing separate from the sensor heads.

Measuring system

A complete system consists of an ultrasonic emitter, an ultrasonic receiver and an evaluation unit. These units have been optimally tuned to one another at the factory and may not be used separately.

Alignment

When adjusting the emitter and receiver, take care to align them as precisely as possible.

Distance of the sensor heads: $d = 20 \text{ mm} \dots 80 \text{ mm}$

Angular tolerance: $\alpha < \pm 2^\circ$

Maximum offset: $s < \pm 2 \text{ mm}$

To ensure their correct function, the sensor heads must be aligned at an angle of $20^\circ \dots 45^\circ$ from vertical onto the paper surface. The paper is guided over the emitter at a distance of $5 \text{ mm} \dots 15 \text{ mm}$. The emitter is installed below in order to prevent dust deposits. Install the sensor heads using the included plastic nuts. The sound cone must be completely covered by the paper. This means that the sensor heads must be installed above the sheet of paper and at least 10 mm away from the side edge of the paper.

Maximum feed speed of the sheet (approximate value)

$$v_{\max} [\text{m/s}] = \text{overlapping of sheets} [\text{mm}] / 5 \text{ ms} \quad (\text{overlapping} > 20 \text{ mm})$$

TEACH-IN

1. After the operating voltage has been applied, a single sheet can be fed in as the first sheet. It will automatically be programmed as a reference value by the system.
2. If a single sheet of paper is located between the ultrasonic emitter and receiver when the operating voltage is turned on, it will automatically be programmed as a reference value by the system.

Automatic learning for thinner types of sheets

If you are inserting a thinner type of sheet, you can dispense with the use of the TEACH-IN signal to program the system. In order to do this, a single sheet of paper must be between the emitter and receiver for at least 10 s .

Automatic learning for thicker types of sheets

If you are inserting a thicker type of sheet but still not one that will result in double-sheet output, you can dispense with learning by means of the TEACH-IN signal. In order to do this, a single sheet of paper must be between the emitter and receiver for at least 10 s .

TEACH-IN for new type of sheet

If you are inserting a new type of sheet that will result in double-sheet output, the system must be reprogrammed. To do this, a single sheet must be placed between the emitter and receiver. After the TEACH-IN signal has been applied, the corresponding reference value will be accepted.

Caution!

The paper sheets may not touch the sensor heads during operation. Depending on physical conditions, reflections on the edge of a single sheet may result in double-sheet output. This is not an error, and can be masked out in the higher-level control system.

Sensor systems for ultrasonic double-sheet monitoring can also be delivered with a customised time response for optimal adaptation to specific applications.

Model number

UDB-18GM35-3E2

Characteristic curves/additional information

Characteristic response curves

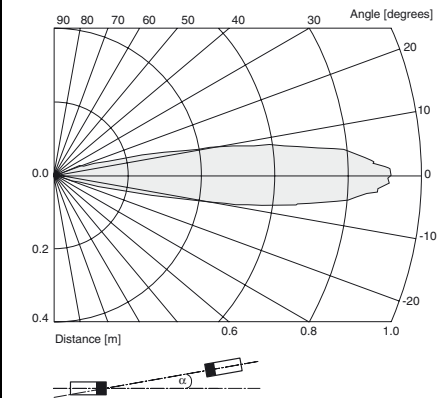

Mounting/Adjustment

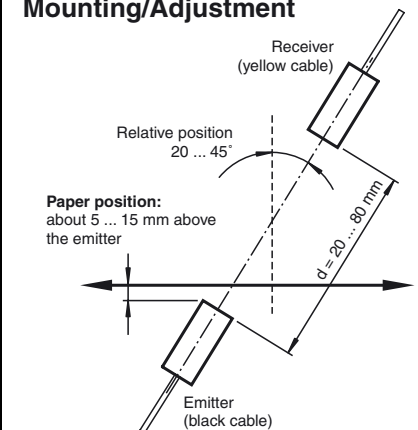

Angular alignment

$$\alpha < \pm 2^\circ$$



Sensor offset

$$s < \pm 2 \text{ mm}$$

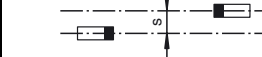

Accessories

Mounting aids

MH-UDB01